

10K Swing Check Valve

10SRBF

B.C.

FF-flanged

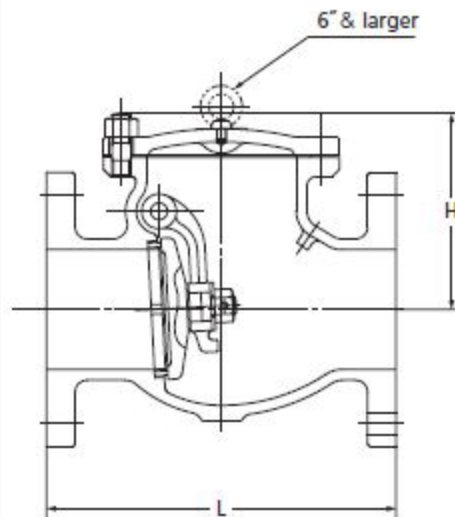

F-F dimension : JIS B 2002
End flanges : JIS B 2239 10K

120°C Static water..... 1.37MPa
220°C Steam, air, gas, oil..... 1.18MPa
300°C Steam, air, gas, oil..... 0.98MPa

- Use for lubricating or hydraulic oil is acceptable. Contact KITZ Corporation for technical advice, if valves are used as heat transfer media.
- Bolting materials will be changed for servicing high temperature exceeding 225°C. Contact KITZ Corporation for detailed information.
- A gasket will be used for sealing the plug for application to high temperature exceeding 260°C. Specify your service temperature in advance. Ensure replacement of plug gaskets on your valve maintenance.

Materials

Parts	JIS material
Body	FCD-S
Cover	FCD-S
Disc	SUS 403 (8"~12": SCPH2+13Cr)
Disc nut	SS 400 (5"~12": SUS 304)
Body seat ring	SCS 1 (5"~12": SUS 403)
Arm	SCS 13A (5"~12": SFVC2A or SCHP2)
Hinge pin	SUS 403
Split pin	SUS 304
Plug	SS 400
Washer	SS 400
Gasket	Asbestos-free
Cover bolt / nut	SS 400

Dimensions

Size	mm										
	mm inch	40	50	65	80	100	125	150	200	250	300
L		165	203	216	241	292	330	356	495	622	698
H		115	120	130	145	160	195	215	255	310	350

NOTE : For flange dimensions refer to Page 40. *RF-flanged ends shall be optionally available.