

CLASS 125

BRONZE Y-PATTERN SWING CHECK VALVE

Screwed cap, Swing type disc,
Threaded ends to BS21 (JIS B0203)

W.O.G. non-shock 1.38 MPa (200 psi), Saturated steam pressure 0.86 MPa (125 psi)

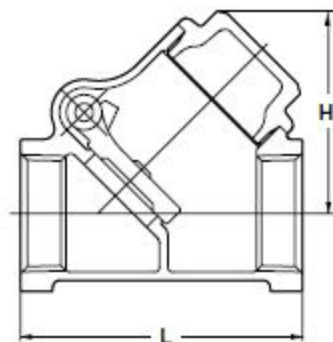

Materials

Parts	Material
Body	Bronze
Cap	Brass
Hinge pin	Copper
Disc	Bronze

Caution

Solder joint end valves should not be used in service where the temperature of line fluid is higher than the softening point of solder.

Fig. YR

- Threaded end to BS21

Dimensions

Nominal Size	Inch	1/2	3/4	1	1 1/4	1 1/2	2	2 1/2	3	mm
	mm	15	20	25	32	40	50	65	80	
L Threaded end to end		56	70	80	95	110	128	158	184	
H Height		40	49	58	71	80	95	114	131	
H Solder		38	47	56	69	77	92	111	127	